



Frontier™ 5706

Multi Centrifuge



Reliable and Compact Multi-Function Centrifuge For Standard Life Science Separation Applications

Frontier 5706 is a small benchtop multi-function centrifuge ideal for a multitude of spin-down applications. Characterized by reliability, various safety features, the ability to accommodate test tubes of various sizes and intuitive operation, Frontier 5706 was built to meet the basic need for liquid separation in the life sciences.

Standard Features Include:

- **Extremely Simple and Intuitive Operation**—With an easy-to-turn control knob, a large LCD display and the capabilities to set and view both speed in rpm and g-force, enjoy precise results and enhanced functionality with extremely simple operation.
- **Compatibility with Test Tubes of Various Sizes**—Frontier 5706 can accommodate all standard tube sizes from 1.5 mL to 50 mL, providing centrifugation for a wide variety of applications. It also has a large capacity, and can hold six 50 mL tubes and twelve 15 mL tubes during one process.
- **Several Safety Features that Protect Against Injury**—Among Frontier 5706's safety attributes are sturdy mechanical lid with locking system and a rotor imbalance sensor that stops the centrifuge if the rotors become imbalanced or sudden shock occurs, protecting the operator from being injured by the high-speed spinning rotors.

Frontier™ 5706 Multi Centrifuge

Model	FC5706	
Speed Range	200 rpm - 6000 rpm; 10 rpm/set	
Maximum RCF	4427 x g; 10 x g/set	
Maximum Capacity (Rotor)	6 x 50 mL	
Temperature range	Air cool	
Running Time	10 sec to 99 hr 99 min 99 sec or continuous	
Noise level (depending on the rotor)	≤ 60 +2 dB(A)	
AC Power	230 V / 50-60 Hz	120 V / 50-60 Hz
Voltage Fluctuation	± 10 %	± 10 %
Current Consumption	0.55 A	1.1 A
Power Consumption	100 W	100 W
EMC	EN/IEC 61326-1 Class B emissions, Basic immunity FCC Class B emissions	
Dimensions (W x D x H)	11.5 x 15.4 x 10.5 in / 291 x 392 x 266 mm	
Net Weight (without rotor)	23 lb / 10.5 kg	
Shipping Dimensions (W x D x H)	15.7 x 21.5 x 16.1 in / 400 x 545 x 410 mm	
Shipping Weight (without rotor)	33 lb / 15 kg	

Approvals

- **Product Safety:** EN 61010-1:2010, EN 61010-2-020:2006
- **Electromagnetic Compatibility:** EN 61326-1:2006, FCC Part 15 Class B

Rotors

- Angle Rotor, 12x15mL 30130877
- Angle Rotor, 6x50mL 30130878
- Swing Out Rotor, 6x5mL 30130880

Accessories

Adapter for Angle Rotor 12x15mL & Angle Rotor 6x50mL

- Adapter for 1.5/2.0mL Tube (6 PCS/Package) 30130886
- Adapter for 5mL Tube (2 PCS/Package) 30130890
- Adapter for 7mL Tube (2 PCS/Package) 30130889

Adapter for Angle Rotor 6x50mL

- Adapter for 15mL Tube (2 PCS/Package) 30130894
- Adapter for 15mL Tube RB (2 PCS/Package) 30130893
- Adapter for 16mL Tube (2 PCS/Package) 30130892
- Adapter for 30mL Tube (2 PCS/Package) 30130891

Buckets

- Replaceable Buckets, For Swing Out Rotor (2 PCS/Package) 30130895

Dimensions

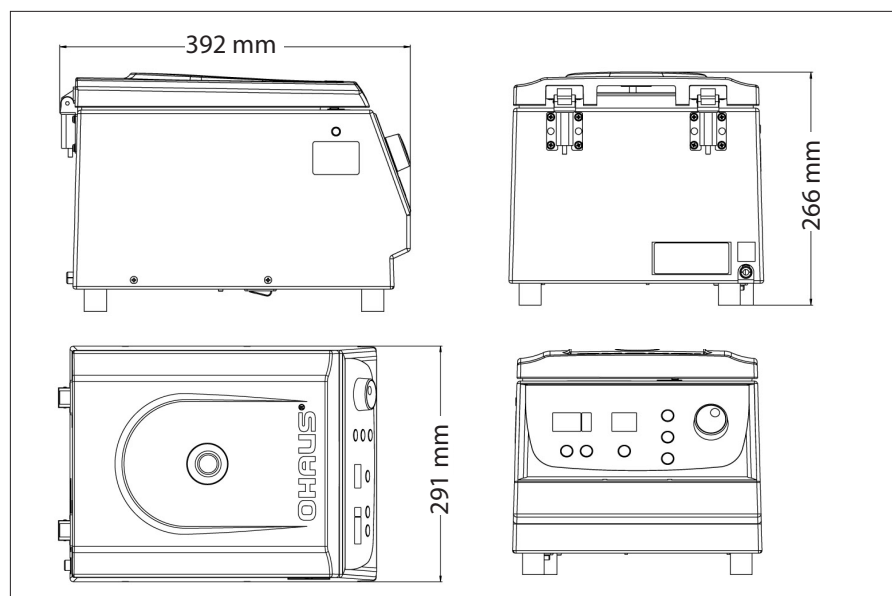

OHAUS CORPORATION
 * 7 Campus Drive
 Suite 310
 Parsippany, NJ 07054 USA
www.ohaus.com
 With offices throughout
 Europe, Asia, and
 Latin America
 * ISO 9001:2008
 Registered Quality
 Management System
 30259432

80774869 © Copyright OHAUS Corporation

